



Scintillation Materials, Detectors and Electronics

Product Data Sheet

DEMOUNTABLE SCINTILLATION ASSEMBLIES

Demountable scintillation assemblies based on NaI (TI), CsI (TI) and CsI (Na) are produced in different modifications. Demountable scintillation assembly consists of a scintillation crystal hermetically packed in a metal container with protective glass and demountable photosensitive device (PMT, SiPM or PSPMT) in protective metal housing. Scintillator is mechanically connected with photosensitive device with a clamping flange. Scintillation crystal is wrapped in reflector material for maximum light detection. The demountable scintillation assemblies can be produced in low-background and ruggedized versions.

Demountable scintillation assembly may include voltage divider, preamplifier, high voltage generator and other electronic modules according to the customer's requirements.



Demountable scintillation assemblies based on alkali halide scintillators are used for registration and gamma radiation spectrometry in the photons energy range from 50 keV to 3.0 MeV under the influence of a radioactive source as well as for kitting of measurement devices for ionizing radiation of general purpose.

The demountable scintillation assemblies can be provided with photosensitive devices of other types than specified. Photosensitive devices supplied by the customer can be used in the assembly. We develop custom-made demountable scintillation assemblies according to customers' specification.

Additional information and features:

- production of any dimensions and design
- aluminum, stainless steel or titanium containers
- reflecting material with the highest characteristics
- photosensitive devices (PMT, SiPM or PSPMT) are individually selected and tested for each scintillator
- using mu-metal magnetic shield for protection from external magnetic fields
- integral or plug-in voltage divider, preamplifier, high voltage generator and other electronic modules for optimal operation
- resistance to mechanical, climatic and temperature loads
- perfect scintillation parameters of products
- ruggedized, low-background and well-type versions are available
- products reliability is confirmed by the warranty



Popular configurations

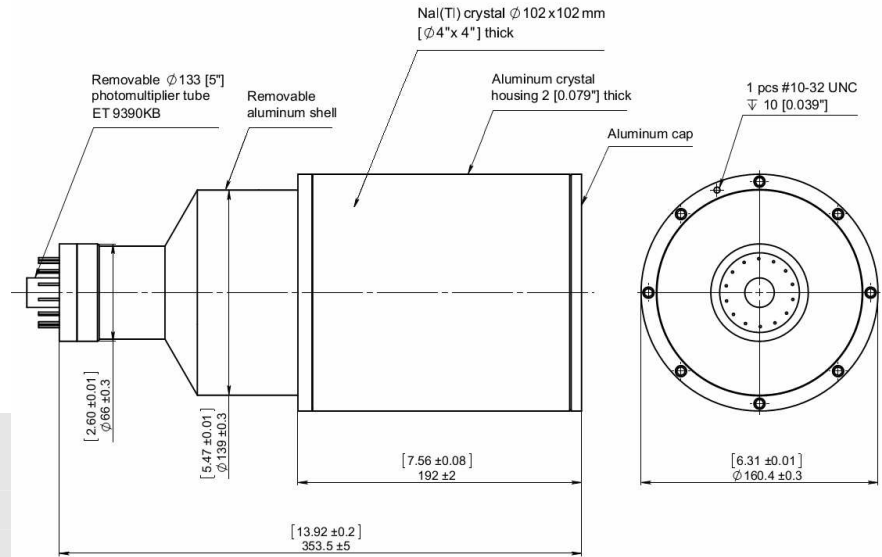

Standard configurations

Model	Crystal size, mm [inches]
16S16/3.5	102x102 [4"x4"]
20S20/5	127x127 [5"x5"]
24S24/5	152x152 [6"x6"]

Model 24S24/5

A well-type receptacle in NaI (TI) scintillation assemblies provides maximum absorption of radiation from a sample by approximating 4p geometry. Scintillation assemblies with well-type crystals are used in medicine, biological research, environmental monitoring, etc. We have different modifications of well-type scintillation assemblies in productions.

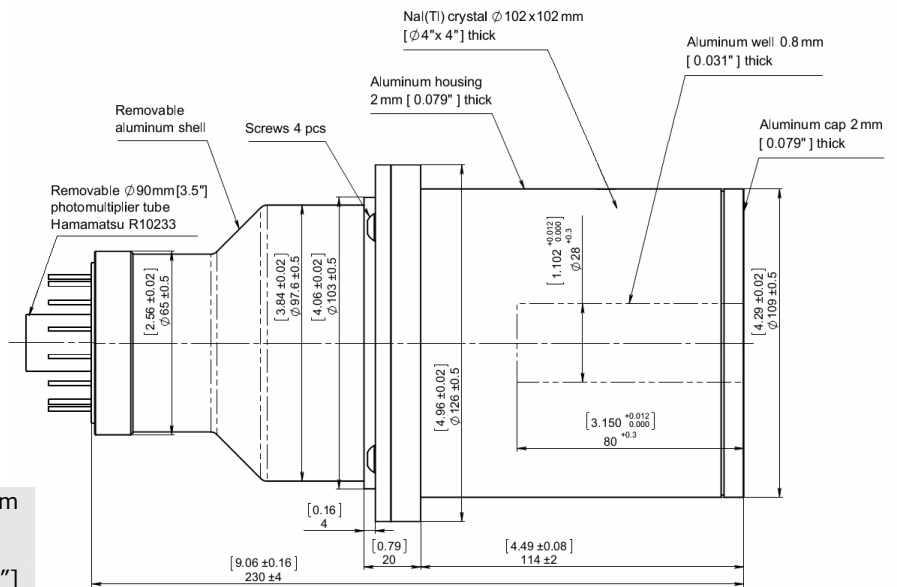

Axial well configurations

Model	Crystal size, mm [inches]
16SW16/3.5.C2	102x102 [4"x4"]
20SW20/5.C2	127x127 [5"x5"]

Model 16SW16/3.5.C2



Ruggedized demountable scintillation assemblies

Demountable scintillation assemblies for geophysical (well logging) and special applications can be produced in ruggedized versions. Ruggedized demountable scintillation assemblies with improved mechanical and thermal characteristics are applied for gamma-ray logging in gas and oil industry.

In order to provide increased mechanical and thermal hardness ruggedized demountable scintillation assemblies are batched with NaI (TI) polycrystals or other scintillation materials, usually CsI (Na), with damping system for qualitative work within assemblies' lifetime.

Low-background demountable scintillation assemblies

For detection and spectrometry of weak ionizing radiation and low activity levels of different radionuclides, low-background demountable scintillation assemblies are used which are characterized by a very low intrinsic background level. The low background is attained by the use of both crystals having a low intrinsic background level and suitable construction materials.